



<b>PRESVLAKA</b>	PRESVLAKA	Mebl-štof; Eko koža (PU);
	ŠAVOVI	U boji presvlake (TT)
	KEDERI	U boji presvlake
	FIKSNA ILI UKLONIVA	Fiksna
<b>PUNILO</b>	JAS. SEDIŠTA	Poliuretanska pena gustine 32 kg/m <sup>3</sup> + sloj akrilnih vlakana gustine 200 gr/m <sup>2</sup>
	JAS. NASLONA	Silikonsko vlakno
	UKR. JASTUCI	-
	KORPUS/RUKON.	Poliuretanska pena gustine 20 kg/m <sup>3</sup>
<b>GEŠTELA</b>	RAM	Čamova, bukova građa, iverica, oplemenjena iverica, lesomit, siva lepenka
	KONSTRUKCIJA	Lepak i klamarice
	SEDIŠTE OSLANJANJE	Elastična gurtina
	NASLON OSLANJANJE	-
<b>MEHANIZAM &amp; DUŠEK</b>	TIP	Makaze na izvlačenje – lift mehanizam
	DUŠEK	Poliuretanska pena gustine 23 kg/m <sup>3</sup>
<b>NOGICE</b>	MONTAŽA	Montirane
	GLAVNA NOG. MAT.	Drvena
	BOJA	Crna ili po želji kupca od raspoloživih nijansi

### RASPOLOŽIVE VERZIJE

ŠIFRA	ELEMENTI FIKSNI	ŠIFRA	ELEMENTI UGAONA GARNITURA	ŠIFRA	OSTALI ELEMENTI
030M	TROSED MEHANIZAM	025	2,5-SED LEVI	031	TROSED LEVI
030	TROSED FIKSNI	025M	2,5-SED LEVI MEHANIZAM	031M	TROSED LEVI MEHANIZAM
020	DVOSED	026	2,5-SED DESNI	032	TROSED DESNI
010	FOTELJA	026M	2,5-SED DESNI MEHANIZAM	032M	TROSED DESNI MEHANIZAM
006	TABURE MAXI	041	PRODUŽENA FOTELJA LEVA	033	TROSED TERMINAL
005	TABURE	042	PRODUŽENA FOTELJA DESNA	033M	TROSED TERMINAL MEHANIZAM

\*Navedene dimenzije u realnosti mogu odstupati u rasponu ±2-3%. Zadržavamo pravo izmene na modelima u cilju poboljšanja njihovih karakteristika.

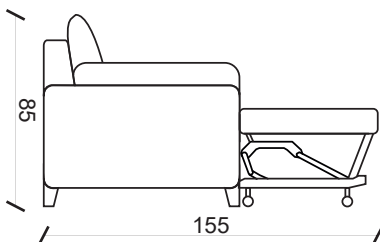
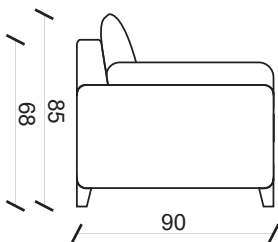

**TROSED FIKSNI**

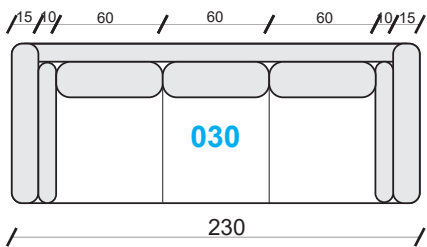

**DVOSED FIKSNI**

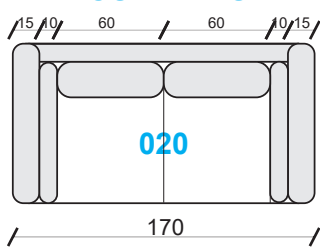

**FOTELJA**

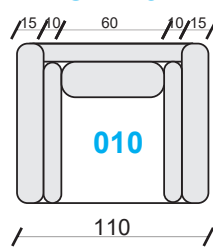

**TROSED LEVI FIKSNI**

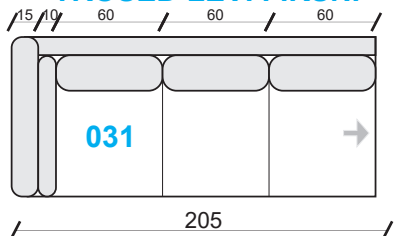

**TROSED DESNI FIKSNI**

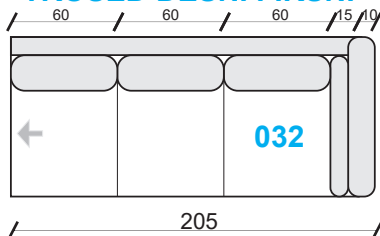

**TROSED TERMINAL FIKSNI**

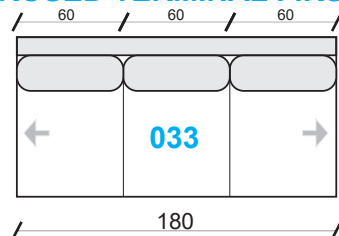

**TROSED LEVI MEH.**

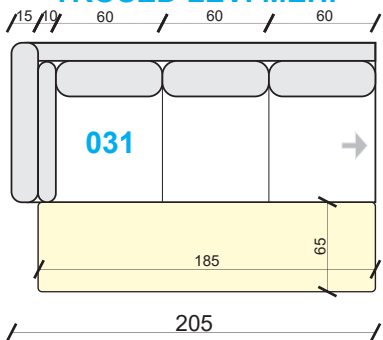

**TROSED DESNI MEH.**

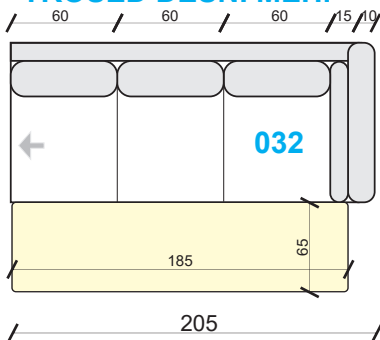

**TROSED TERMINAL MEH.**

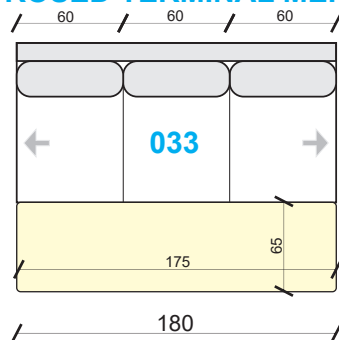

**TROSED MEHANIZAM**

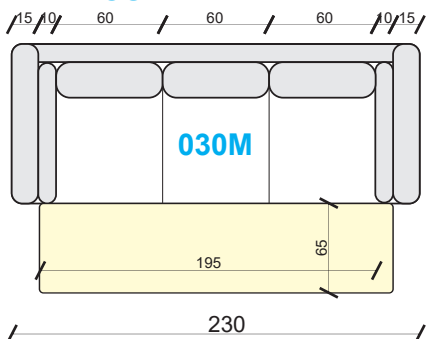

**2,5-SED LEVI MEH.**

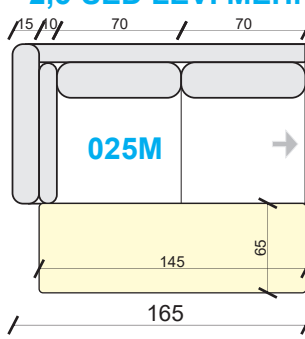

**2,5-SED DESNI MEH.**

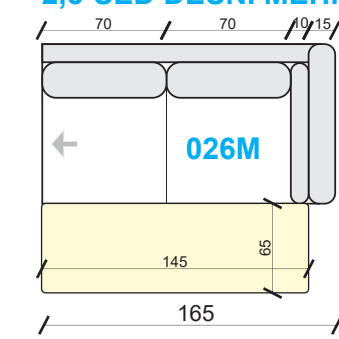

**2,5-SED LEVI**

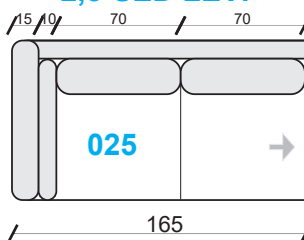

**PROD. FOT. DESNA**

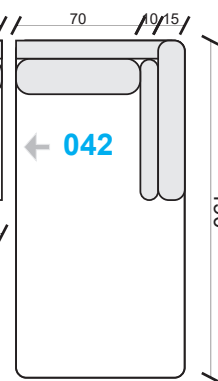

**PROD. FOT. LEVA**

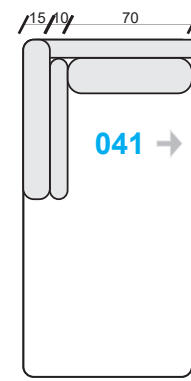

**2,5-SED DESNI**

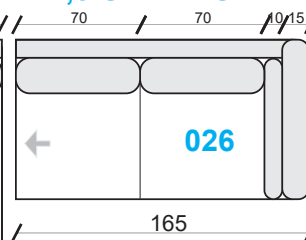

**TABURE MAXI**

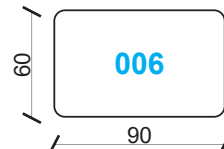

**TABURE**

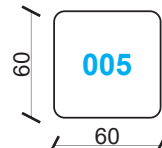

260

95

95

260

60